

SMARTMELT SERIES

The New Generation of adhesive melters: 15, 30, 65 & 120L

Valco Melton's SmartMelt™ Series has been specifically designed for easy plug-n-play upgrades of additional heating zones, flow control, pumping stations, and more. This fully customizable unit permits an accurate control of the glue applied during machine ramp up and down.



Key highlights:

- Connect anywhere with optional wifi remote connectivity and online technical assistance
- All electronics are "Off the Shelf" commercially available components: PLC with 5.7" Color Touch Screen, IO boards, drives, AB solid state relays etc. non proprietary electronics
- Analog and digital signals on Harting connector interface 100% compatible
- Expand the unit's control capabilities with the addition of compact Smart boxes. Each box is controlled from the same melter. No re-engineering required
- Main machine network communication protocols (Profinet and Ethernet) are 100% compatible

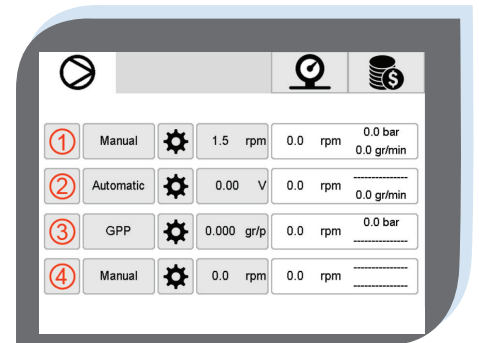

The pump control can be programmed in grams per product or grams per square meter, depending on each application's specific requirements.

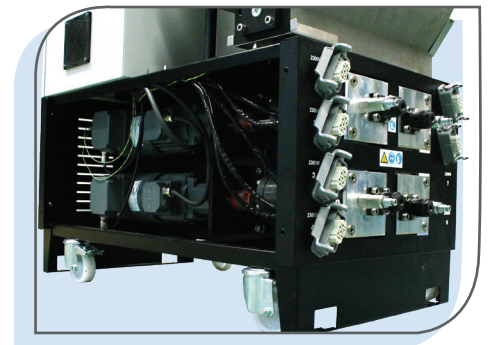

Reduce space on the floor with its compact design as the motors are vertically stacked in pairs



Two main heated grids on bottom on the tank to prevent adhesive degradation

SMART ARCHITECTURE

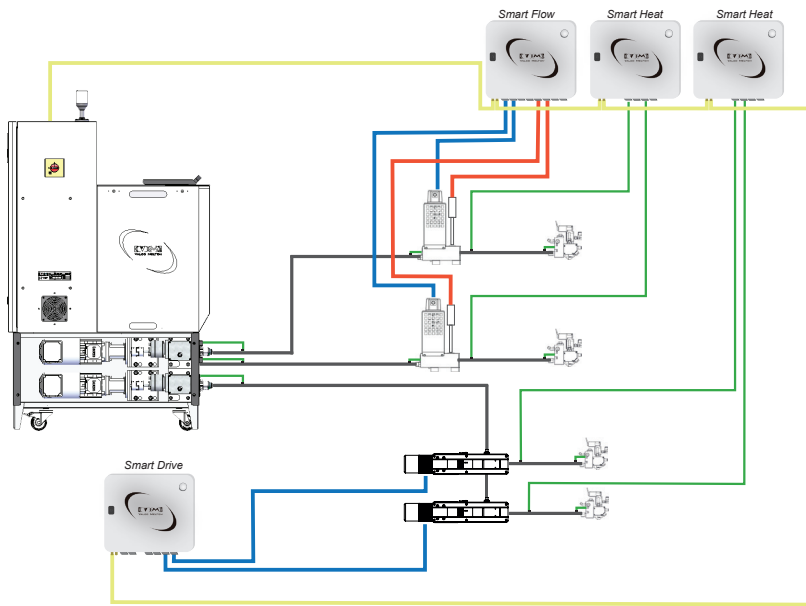

Flexibility for future expansions

Valco Melton's Smart Series offers the possibility for easy future upgrades through a connecting communication cable. Each tank is capable to expand its control capability adding compact **Smart Boxes**:

- Up to 2 Smart Drive compact boxes with 2 frequency drives and 4 inputs for pressure reading to add extra pump control and process diagnostics
- Up to 2 Smart Heat compact boxes for extra temperature channels with 4 hose/ head connectors
- Up to 2 Smart Flow compact boxes, each with up to 4 flow meters and 4 pressure transducer

Technical Specifications

SmartMelt Series				
System	SmartMelt 15	SmartMelt 30	SmartMelt 65	SmartMelt 120
Tank Capacity	15L	30L	65L	120L
Melting Capacity	17kg/h	25kg/h	50kg/h	95kg/h
Max. Pumping Capacity per Pump	48kg/h	48kg/h	48kg/h	90kg/h
Number of Pumps	Up to 4			
Working Temperature	30-240°C			
Electrical Connection	230 III + T, 400 III + N + T			
Max. Working Viscosity	90,000cps			
Max. Working Hydraulic Pressure	80 bar			
Max. Electrical Consumptions	3400w	4600w	6000w	12300w
Electrical Consumption (Double or single stream pump)	1280w			

Max. channel power	Ni120	PT100
Hose / Gun	2300w	2300w

Dimensions (mm)	System 15/30/65	System 120
A	955	1538
B	525	602
C	1460	1521

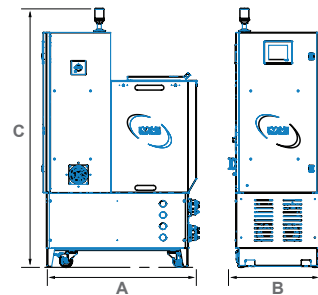

For more information, visit valcomelton.com or contact your local representative
 World Headquarters: Cincinnati, OH, USA • Tel: +1 513 874 6550
 Europe Headquarters: Orkoien, Spain • Tel: +34 948 321 580



Locations

inquiry@valcomelton.com

KCB 0000214 EN 003